



# Traffic Light Bases

From: **ALLOY CASTINGS CO., INC.**

Quality Aluminum Castings Since 1948

151 West Union Street • P.O. Box 473 • East Bridgewater, MA 02333-0473

Telephone: (508) 378-2541 • FAX: (508) 378-1240

www.alloycastings.com

## Material Specifications

Aluminum Alloy 356 (ASTM SG70A)

Conforming to ASTM Spec B26 for Sand Castings with Minimum Yield

**Strength:** Tension: 18 KSI    Compression: 19KSI    Shear: 17KSI

**All hardware 304 Stainless Steel.**

**Base contains internal grounding stud.**

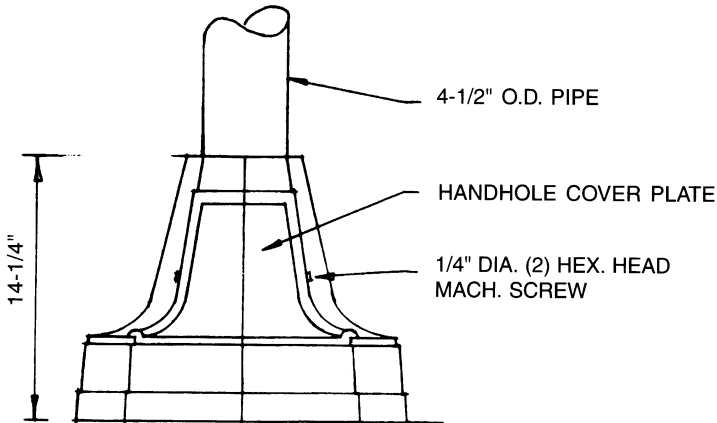

**ELEVATION**

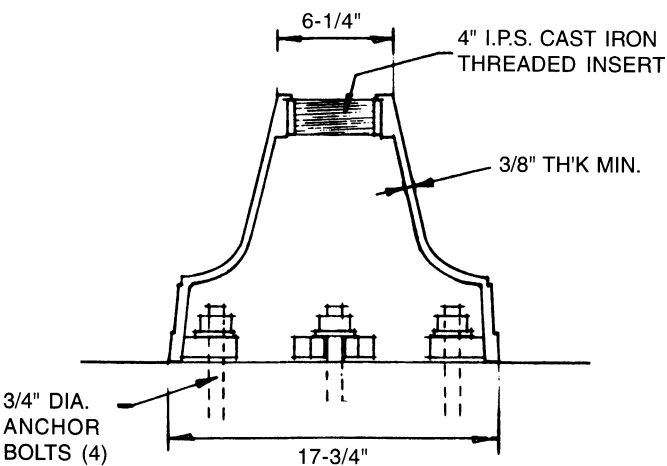

**SECTION**

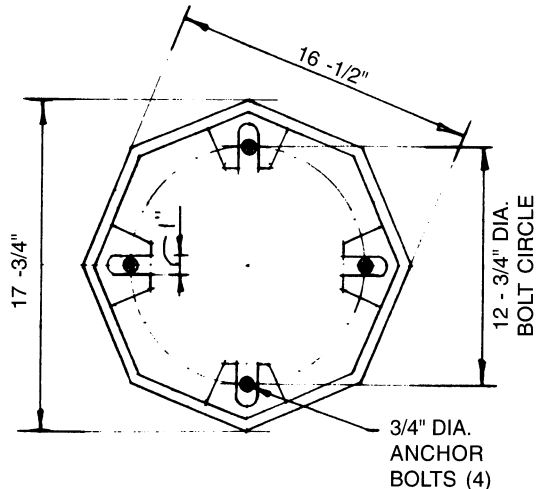

**Bolt Circle 12-3/4" DIA.**  
**BOTTOM PLAN**